

JBC

www.jbctools.com

INSTRUCTION MANUAL



AL

Auto-Feed Soldering Station

This manual corresponds to the following references:

- AL-1A (120V)
- AL-2A (230V)
- AL-9A (100V)

Packing List

The following items are included:



Control Unit 1 unit



Stand 1 unit
Ref. AL-SF



Auto-Feed Iron 1 unit
Ref. AL250-B

*Includes: Cartridge C250403 and
Cartridge Guide Ref. 0002401
(Ø 0.9 - 1 mm / 0.035 - 0.04 in)*



Manual Tip Cleaner 1 unit
Ref. CL8499



Metal Brush 1 unit
Ref. CL6217



Sponge 1 unit
Ref. S0354



Solder Reel Stand 1 unit
Ref. 0008745



Allen Key 2.5mm 1 unit
Ref. 0780493



Power Cord 1 unit
Ref. 0023715 (120V)
0023714 (230V)
0024092 (100V)



Manual 1 unit
Ref. 0026948

Features and Connections

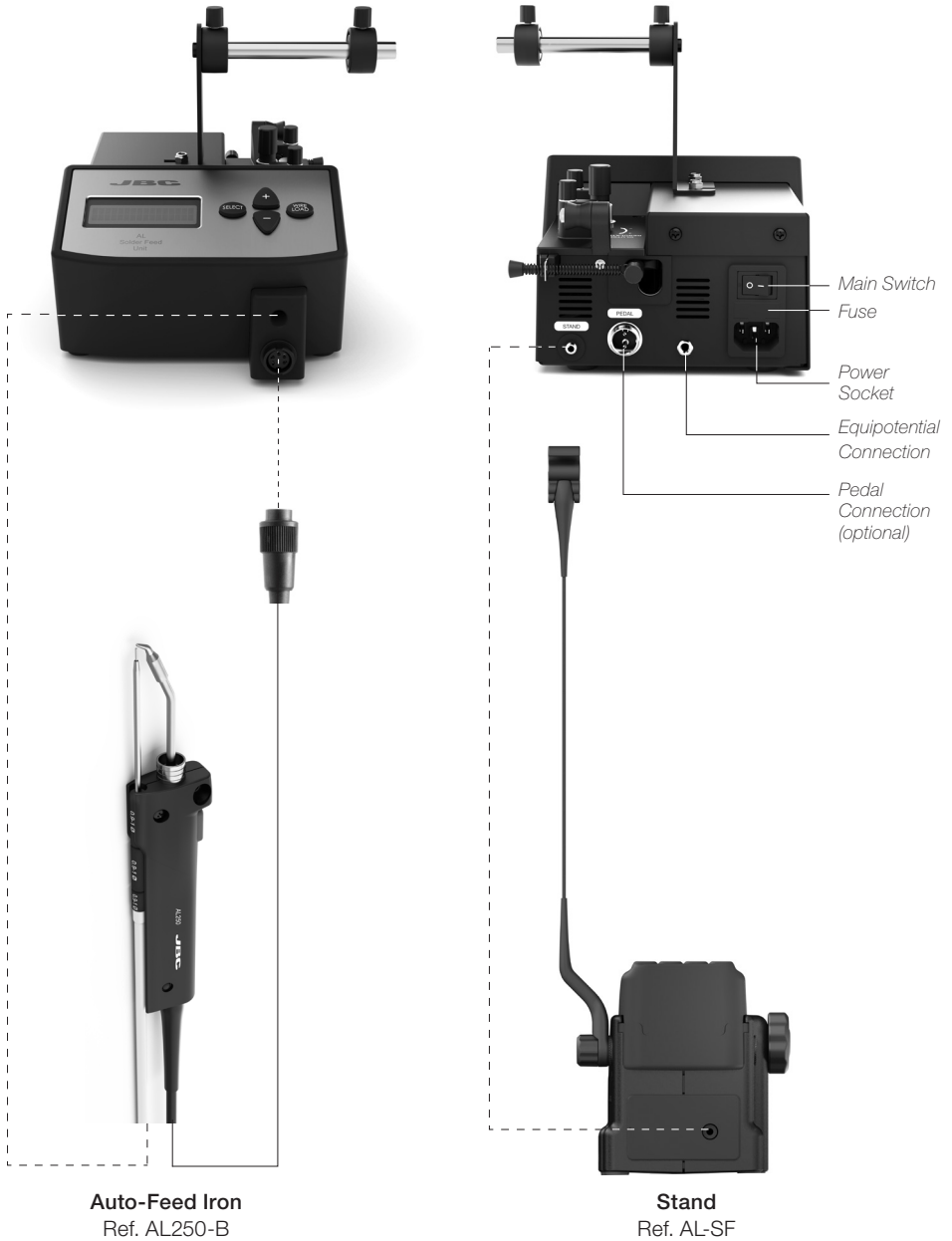

Reel Stand Assembly

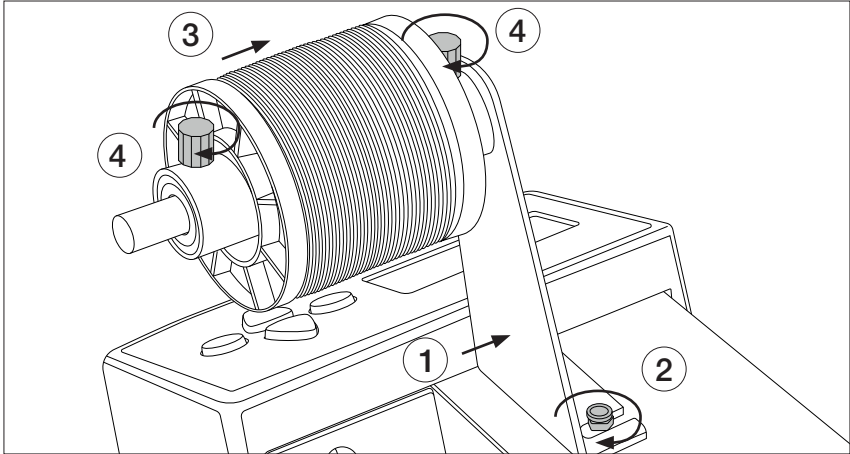

1. Assemble the Reel Stand to the Station
2. Tighten the screws.

3. Assemble the Solder Reel
4. Tighten the screws.

Adjusting System Assembly

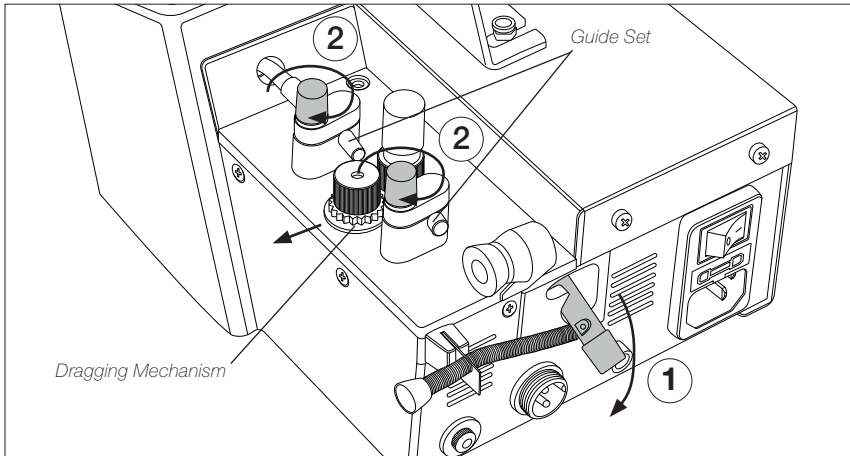

1. Open the dragging mechanism moving the lever downwards (the dragging mechanism releases the solder wire).
2. Place the guide set and tighten the screws.

3. Take the solder wire from the reel until the guide tube start.
4. Close the dragging mechanism moving the lever upwards (the dragging mechanism moves toward the Solder wire).

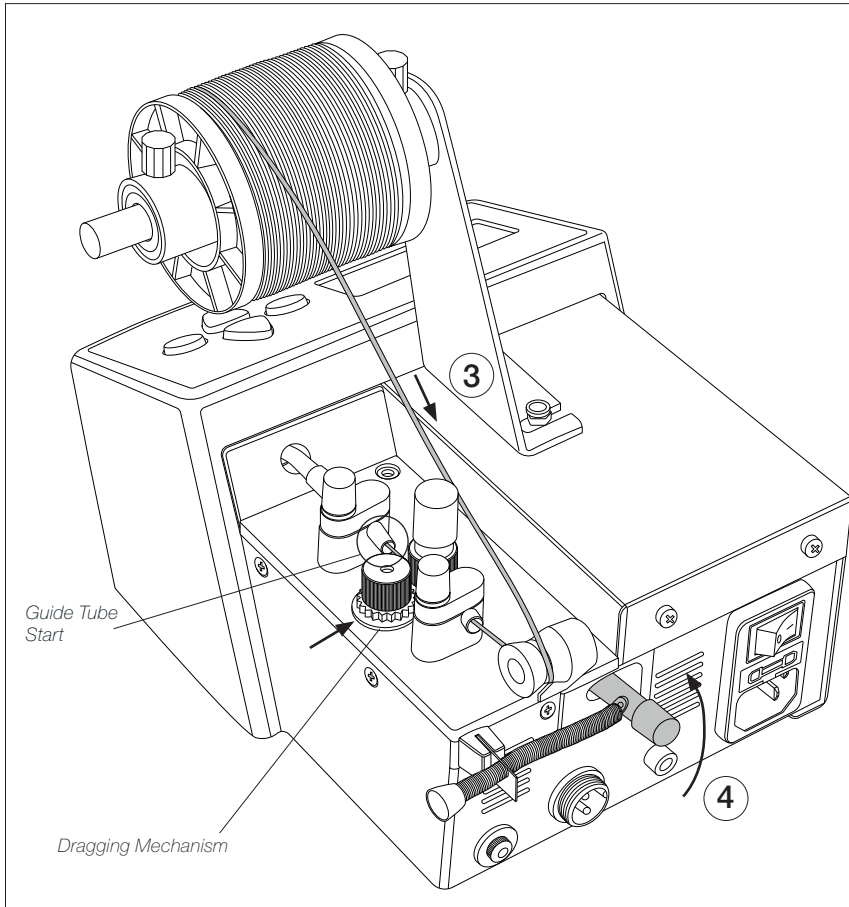

5. Connect the handpiece to the station and switch the station on. With the handpiece out of the stand, press the WIRE LOAD key at the station till the solder wire comes out at the guide tube end.

LOADING SOLDER WIRE

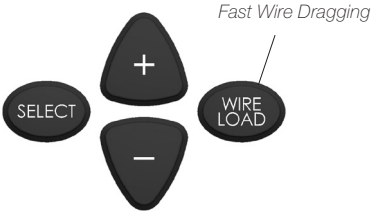

Clutch Regulation

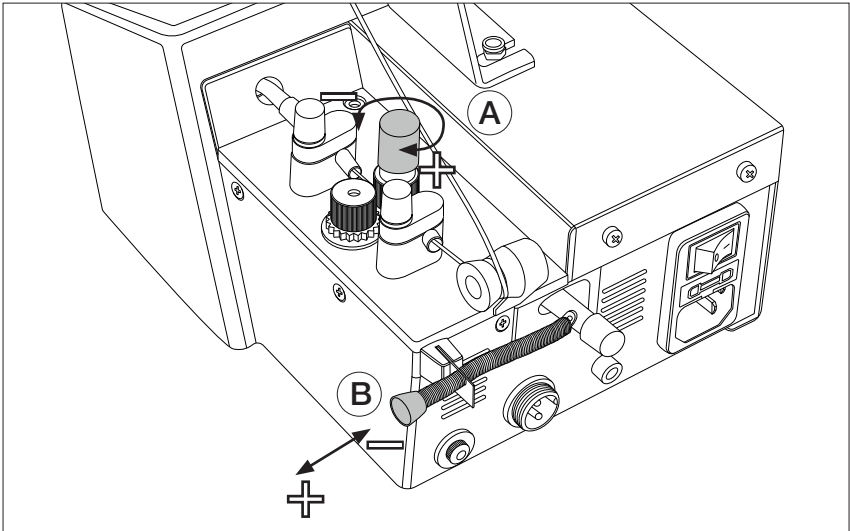

- A. Adjust the dragging strength to enable the solder wire to be passed on properly and to avoid any jamming or clogging.
- B. Fix the dragging mechanism by tighten more or less the sprung element.

Control Screen

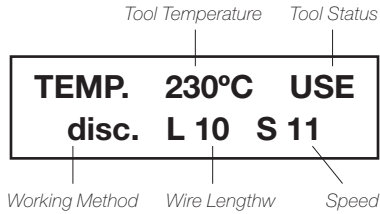

There are 4 tool status:

- USE (Use).** The tool is ready to work.
- STD (Stand).** The tool is placed in the stand but still not in the sleep mode.
- SLP (Sleep).** The tool is in the sleep mode in the stand, its temperature has dropped till the sleep temperature.
- OL.** The power circuit is overheated. The power is temporarily not supplied.

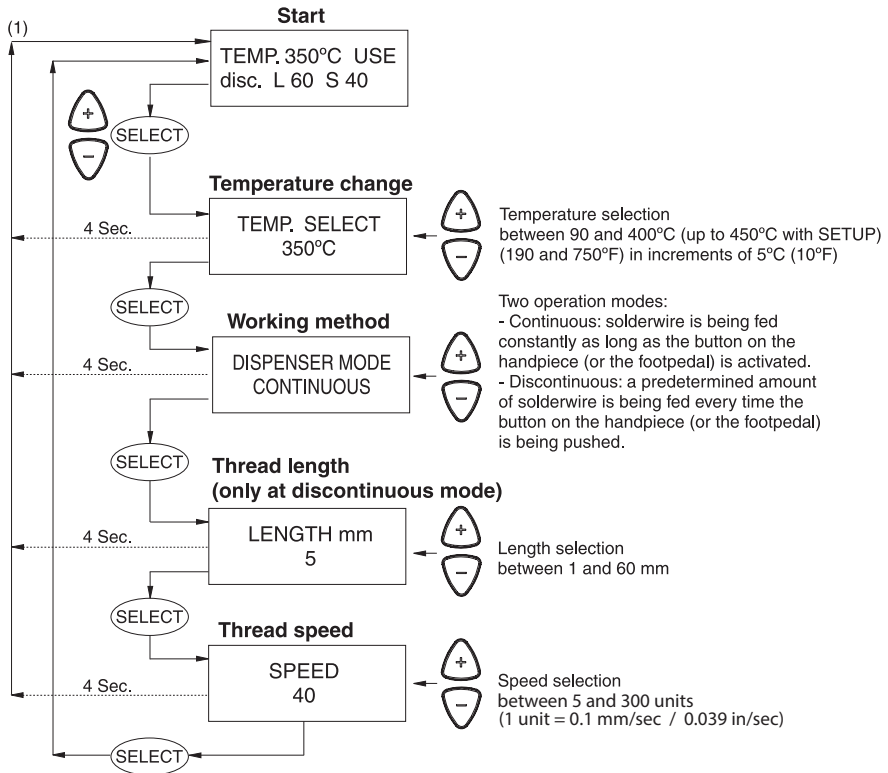

(1) After 4 seconds without pushing buttons, initial screen will be displayed.

Troubleshooting

Station troubleshooting available on the product page at www.jbctools.com

Parameters Modification of the Tool and the Station

To enter into this mode, you must hold the **SELECT** key for **3 seconds**.

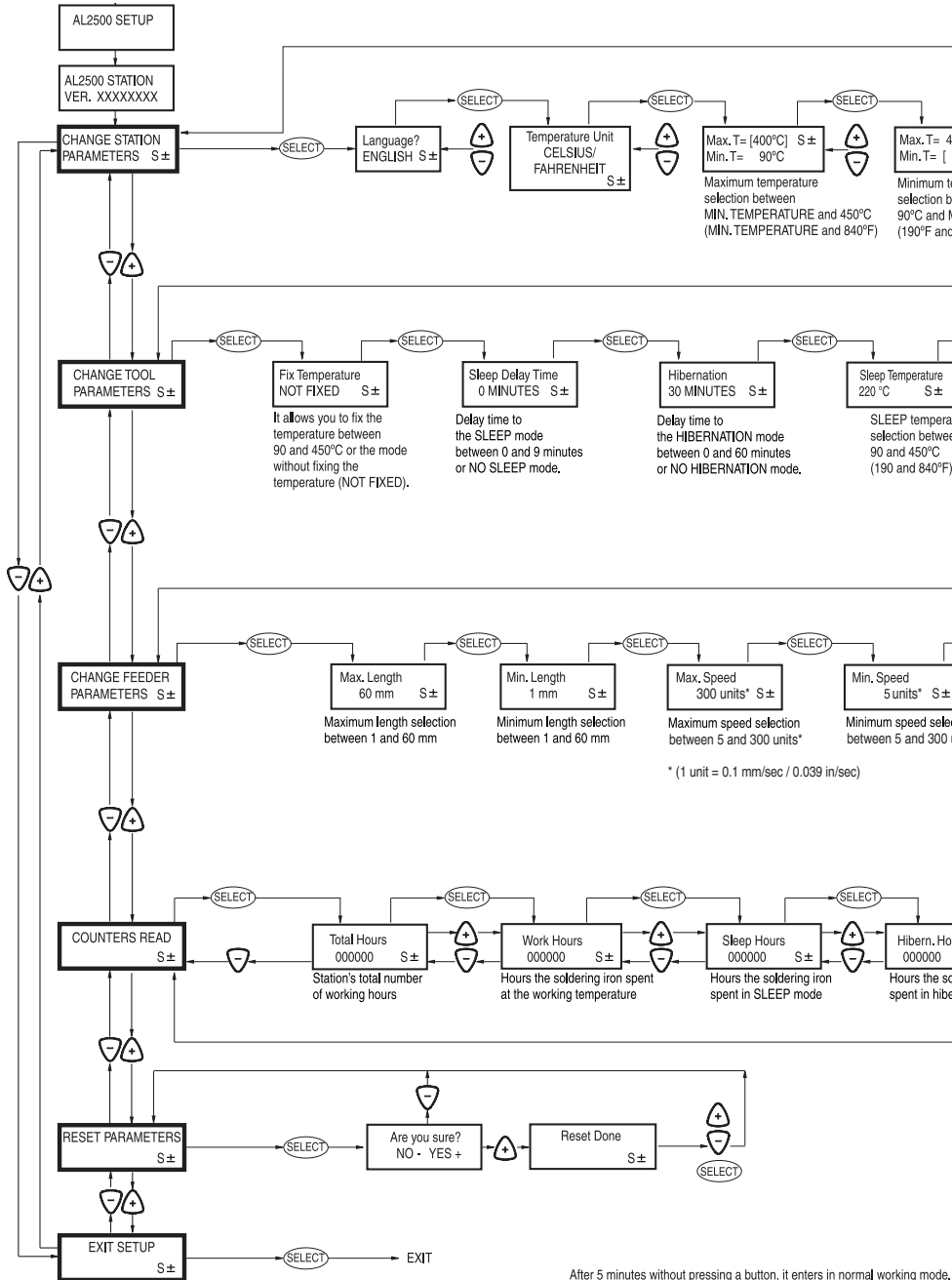

After 5 minutes without pressing a button, it enters in normal working mode.

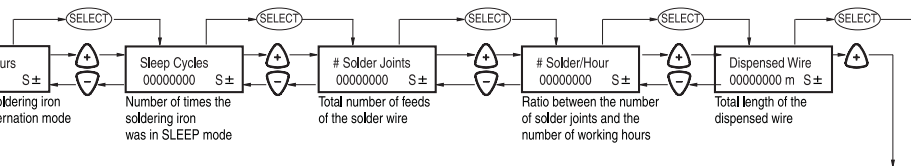
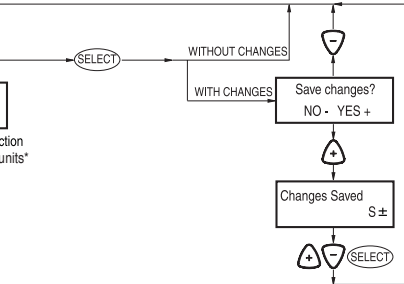
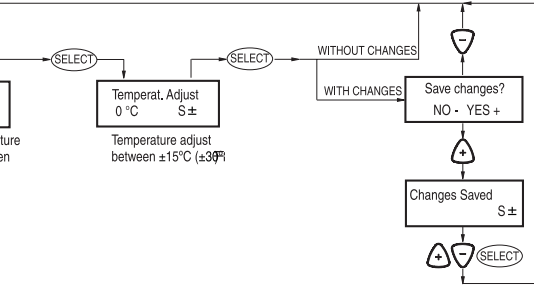
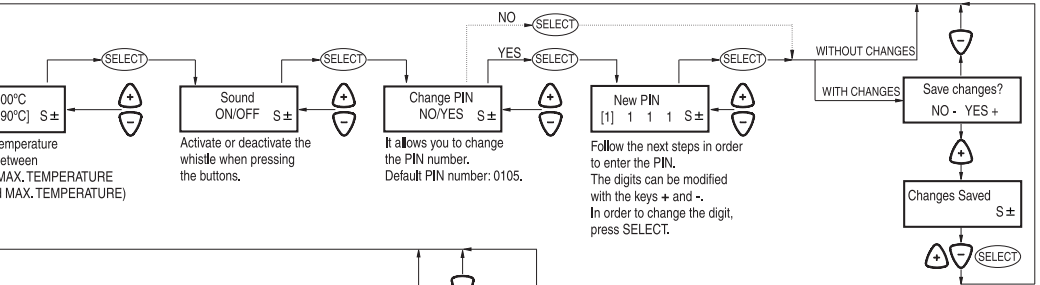

The PIN number must be entered when you need to change a station parameter, Default PIN number: 0105.
You will have to enter the PIN the first time you need to change a parameter as long as you don't leave the SETUP mode

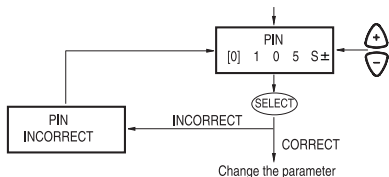

Follow the next steps in order to enter the PIN.
The digits can be modified with the keys + and -. In order to change the digit, press SELECT.

Maintenance

Before carrying out maintenance, always switch the device off and disconnect it from the mains. Allow the equipment to cool down.

- Clean the station screen with a glass cleaner or a damp cloth.
- Use a damp cloth to clean the casing and the tool. Alcohol can only be used to clean the metal parts.
- Periodically check that the metal parts of the tool and stand are clean so that the station can detect the tool status.
- Maintain tip surface clean and tinned prior to storage in order to avoid tip oxidation. Rusty and dirty surfaces reduce heat transfer to the solder joint.
- Periodically check all cables and tubes.
- Replace a blown fuse as follows:



1. Pull off the fuse holder and remove the fuse. If necessary use a tool to lever it off.

2. Insert the new fuse into the fuse holder and return it to the station.

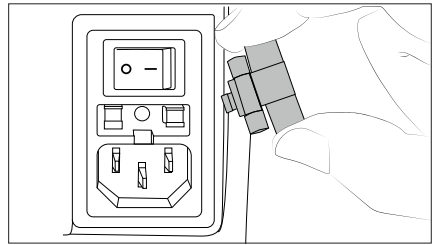
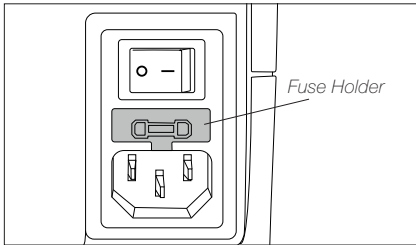

- Replace any defective or damaged pieces. Only use original JBC spare parts.
- Repairs should only be performed by a JBC authorized technical service.

Safety



It is imperative to follow safety guidelines to prevent electric shock, injury, fire or explosion.

- Do not use the units for any purpose other than soldering or rework. Incorrect use may cause fire.
- The power cord must be plugged into approved bases. Be sure that it is properly grounded before use. When unplugging it, hold the plug, not the wire.
- Do not work on electrically live parts.
- The tool should be placed in the stand when not in use in order to activate the sleep mode. The soldering tip, the metal part of the tool and the stand may still be hot even when the station is turned off. Handle with care, including when adjusting the stand position.
- Do not leave the appliance unattended when it is on.
- Do not cover the ventilation grills. Heat can cause inflammable products to ignite.
- Avoid flux coming into contact with skin or eyes to prevent irritation.
- Be careful with the fumes produced when soldering.
- Keep your workplace clean and tidy. Wear appropriate protection glasses and gloves when working to avoid personal harm.
- Utmost care must be taken with liquid tin waste which can cause burns.
- This appliance can be used by children over the age of eight and also persons with reduced physical, sensory or mental capabilities or lack of experience provided that they have been given adequate supervision or instruction concerning use of the appliance and understand the hazards involved. Children must not play with the appliance.
- Maintenance must not be carried out by children unless supervised.

Specifications

AL-1A 120V 50/60Hz. Input fuse: T2A. Output: 23.5V

AL-2A 230V 50/60Hz. Input fuse: T1A. Output: 23.5V

AL-9A 100V 50/60Hz. Input fuse: T2A. Output: 23.5V

- Temperature Range: 90 - 450 °C / 190 - 840 °F
- Output Peak Power: 130W
- Tip to Ground Resistance: <2 ohms
- Tip to Ground Voltage: <2mV RMS
- Ambient Operating Temp: 10 - 50 °C / 50 - 122 °F
- Diameter of Solder Wire: 0,4 - 1,8 mm / 0.02 - 0.07 in
- Capacity of Solder Reels: up to 2 Kg / 4.41 lb
- Wire Length: 1 - 60 mm / 0.04 - 2.36 in
- Programmable Dispensing Speed Range: 5 - 300 units (0.5 - 30 mm/sec. / 0.02 - 1.18 in/sec.)
- Control Unit Dimensions / Weight: 235 x 170 x 112 mm / 9.25 x 6.69 x 4.41 in
(L x W x H) 5,8 Kg / 12.9 lb

- Total Package Dimensions / Weight: 368 x 368 x 195 mm / 6.7 Kg
(L x W x H) 14.49 x 14.49 x 7.68 in / 14,8 lb

Complies with CE standards.
ESD protected.

JBC

Warranty

JBC's 2 year warranty covers this equipment against all manufacturing defects, including the replacement of defective parts and labour.

Warranty does not cover product wear or misuse.

In order for the warranty to be valid, equipment must be returned, postage paid, to the dealer where it was purchased.

Get 1 extra year JBC warranty by registering here:

<https://www.jbctools.com/productregistration/>
within 30 days of purchase.



This product should not be thrown in the garbage.

In accordance with the European directive 2012/19/EU, electronic equipment at the end of its life must be collected and returned to an authorized recycling facility.

